

SILENTMASTER®

MANUFACTURED BY
MD
CENTRAL VACUUMS

SPECIFICATIONS FOR MODEL

S44

#S2155ADxx 240 VOLT

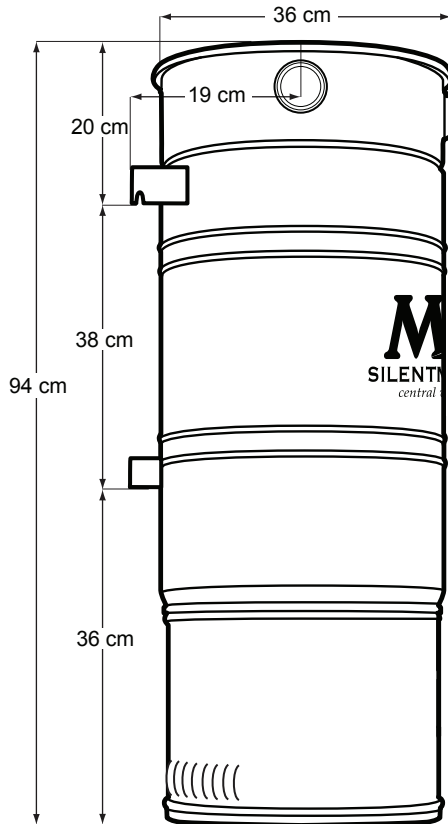

SIDE VIEW

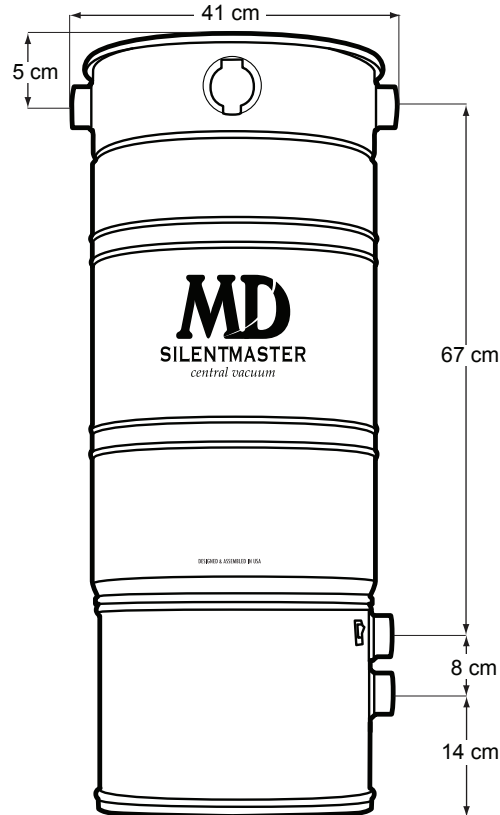

FRONT VIEW

PERFORMANCE

Sealed Vacuum 3733 mm
CFM 61.1 L/sec
Air Watts 630
Volts 240
Amperage 8.0
Quietness 68dBA
Coverage 743 m²*

*Excellent performance for homes up to 743 m². Consider all factors when choosing a unit including air watts, altitude, usage, complexity of pipe installation, furthest inlet from unit, noise level, filtration, manufacturing origin, construction, and budget.

FEATURES

Motor: High performance, 2-stage motor with superior efficiency and power.
Filtration: HyperFlow™ disposable 45-liter bag.
Intakes: Right & left intakes. Utility valve.
Construction: Durable powder-coated all steel body.
Overload: Heat protection resettable minibreaker.
Warranty: Six Years + Lifetime on manufacturing. Find a better one and we'll match it.
Dims/Weight: 36 cm Diameter, 97 cm Tall, 19 kg.
Accessories: All MD accessories and kits are compatible and are sold separately.
Optional: Air Relief Valve, Mufflers. Closed bag filtration.

INSTALLATION

Electrical:
Operates on 220V-240V.
50/60HZ, 10 amp circuit.

Last 2-digits of part number will specify country cord configuration.

Mounting:
Two-stud 43 cm wide bracket.
Left/right variable positioning.
Mount 15 cm off ground. Leave 61 cm above unit.

Venting:
Exterior venting not necessary. 9 m maximum line if venting.

PROJECT		LOCATION	
DEALER		DATE / PRICE	

Designed & Assembled in USA

WWW.BUILTINVACUUM.COM/SILENT_MASTER

M.D. Manufacturing, Inc. 800.525.2055
34970 McMurtrey Ave. 661.283.7550
Bakersfield, CA 93308 FAX 661.283.7554